

Maximizing your reference multimeter, minimizing measurement uncertainties

Application Note

Introduction

Modern precision digital multimeters are sophisticated measuring instruments offering more than just the ability to measure voltage, current and resistance. More recently, a new type of precision multimeter, the Fluke Calibration 8508A Reference Multimeter, has been developed with the accuracy and stability of metrology grade instruments approaching measurement levels available from the standards used to calibrate them. Such high performance allows these multimeters to be used in place of many traditional laboratory instruments such as Kelvin-Varley dividers, null detectors, resistance bridges and even PRT (Platinum Resistance Thermometer) calibrators. Not only do metrology grade multimeters provide sufficient precision, they also bring a significant improvement in usability and throughput compared to traditional techniques—the latter being of great importance in today's economic climate where calibration laboratories of every type are challenged to meet technical and business objectives alike. Instrumentation designers pay careful attention to maximizing the functionality of the instruments, while at the same time ensure ease of use. However, these sophisticated instruments offering comprehensive capability can appear complex to users. This application note sets out to simplify and explain how these various 8508A Reference Multimeter features can be used to maximize your lab's efficiency.

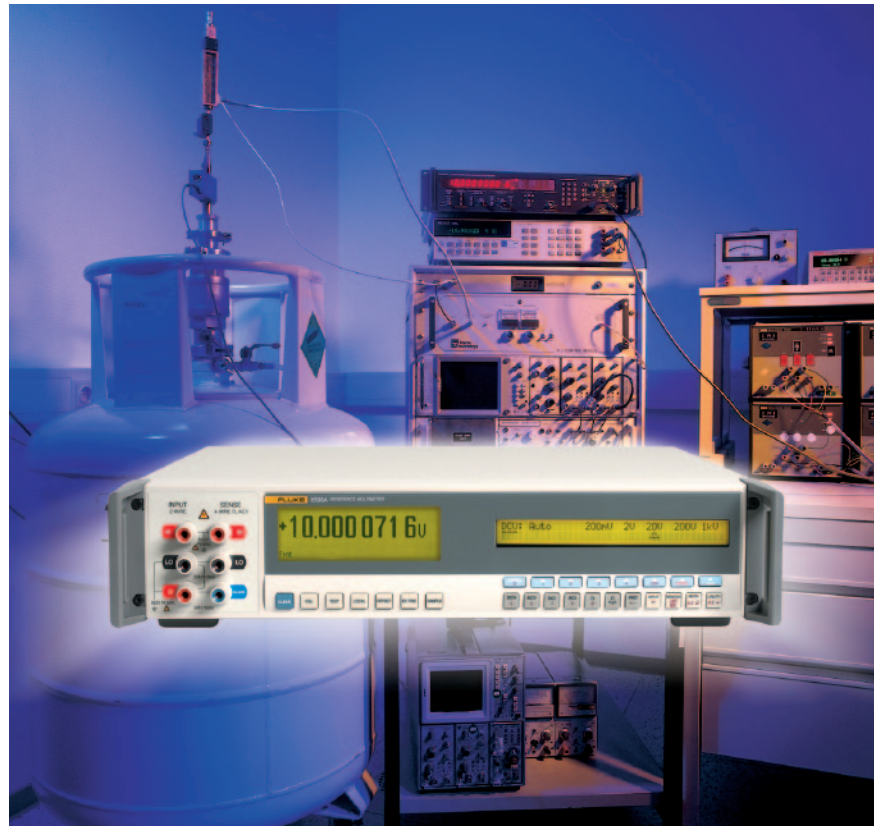

Precision multimeter architecture

In principle, the architecture of a reference multimeter is no different to that of a simple handheld. A block diagram is shown in figure 1. The key element is the analog to digital converter (adc), defining the basic capability to take an electrical signal and provide a digital (numeric) representation. Noise performance, stability, linearity, scale length, resolution, and speed vary tremendously from one instrument design to another. Reference metrology grade multimeters use an

integrating adc where the input signal is effectively compared to an internal reference through charge balance in an integrator circuit. Up to 8.5 digits resolution can be achieved with linearity better than 0.1 ppm of full scale over a scale length of 2×10^8 counts. For dc voltage measurements the input signals are scaled by a combination of attenuators and low noise amplifiers in the dc pre-amp before being presented to the adc for conversion. A low pass filter at the dc pre-amp output, which the user can enable or disable, provides means to

remove unwanted ac signals that may be present on the input. For ac voltage measurement, another signal path, also with signal scaling, uses an rms to dc converter to generate a signal representing the rms value of the input, which in turn is measured by the adc. To perform current measurements the current converter circuit incorporates current shunts that produce a voltage proportional to the current input for measurement by either the dc or ac voltage sub-systems. By employing appropriate design techniques, the input burden voltage that the multimeter presents at its input terminals when measuring current can be essentially isolated from the voltage developed across the internal current shunts, reducing the disturbance (burden voltage) that it presents to the source of current being measured. Resistance measurement capability is provided by an internal current source, generating a range of stable constant currents, that, together with the various voltage ranges, allow resistance to be measured by the simple application of Ohms law. In the case of the new 8508A Reference Multimeter, ranges are extended from 2 Ω to 20 GΩ full scale. The input switching design allows the reference multimeter to have two sets of input terminals, one on the instrument front panel and one on the instrument rear panel. Both sets of terminals are specified to full 1000 V rms rating. With two channels, ratiometric measurements can be performed easily in both the voltage and resistance functions.

ADC operation – Choosing the appropriate configuration for the measurement

The multi-slope integrating adc is capable of extremely high resolution with linearity better than 0.1 ppm of full scale. However, high resolution can only

be achieved at relatively long integration times. In addition to trading off conversion speed and resolution, the integration time has a direct impact on noise rejection. The integration itself effectively averages any ac or noise content in the signal being measured, reducing variation in the displayed reading. It can also be used to reject unwanted line frequency signals present on the input being converted. These unwanted signals effectively appearing in series with the input are commonly known as series mode noise. If the integration time is equal to an exact multiple of the line period, the unwanted line frequency signal integrates out to zero. The user is able to select the resolution and, in the 8508A, can also choose between a ‘normal’ and ‘fast’ adc mode, thereby effectively determining the integration time. Because the adc integration time is related to the power line frequency, the user must ensure the reference multimeter is configured correctly for the line frequency of the power supply to which it is connected. This is normally set during manufacture, but can also be set by the user. In the dc voltage function the 5.5 digit ‘fast’ mode has an integration time of 3.3 ms at 50 Hz and 60 Hz line operation. For all the other combinations of resolution and adc normal/fast selection, the integration time is a multiple of power line period. Provided the user correctly configures the reference multimeter for line frequency the adc will provide rejection of line related signal pickup in all modes except 5.5 digit ‘fast’. Up to 80 dB of rejection at line frequency multiples is typically achieved. Failure to set the correct line frequency will result in excessively noisy readings when series mode line pickup is present.

Choosing a higher resolution mode will effectively mean choosing a longer integration

time, and the signal will be ‘averaged’ within the adc integrator for longer. In addition to the higher resolution, the result is lower reading to reading runaround (noise) and a lower effective bandwidth. At the higher resolutions multiple adc cycles are digitally averaged to provide a single displayed reading. The user can also employ the reference multi-meter’s math modes to digitally average readings, allowing flexibility in the trade off between effective noise bandwidth and measurement time. Choice of most appropriate mode will depend on the application, required resolution and signal characteristics. For most calibration applications the 7.5 digit ‘fast’ mode is appropriate, producing readings with a 1280 ms conversion time at 50 Hz line (1067 ms at 60 Hz). It should be noted that the effective read rate, with the reference multimeter free running in internal trigger mode, may not be as fast as expected, especially when considering the conversion time alone. This is because the adc conversions are triggered by an internal clock at approximately 2 Hz. Achieving a faster read rate requires use of an external hardware trigger signal or triggering from the IEEE488 remote interface. This is equally applicable to measurements made in the resistance function, which utilizes the dc voltage measurement sub-system.

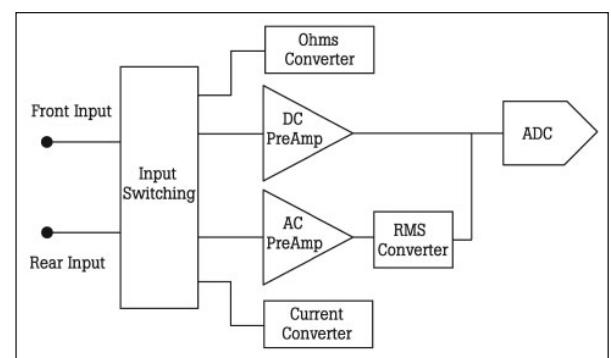

Fig. 1 Simplified DMM block diagram.

Practical dc applications

Typical metrology applications include comparing voltage standards and voltage ratio measurements. For voltage standards, the comparison will typically be of two or more voltages at nominally the same level e.g. comparing two or more 1 V standards with a microvoltmeter or null detector. Provided that the meter is sensitive enough and the difference between the references is less than 10 μ V, this simple detector can give very good results and is able to resolve differences as small as 200 nV (0.2 ppm of 1 V). However, if the reference standards have a large voltage spread the differences could be as large as a millivolt. A typical microvoltmeter under these conditions would only resolve 20 μ V on its 1 mV range, due to the fundamental limitations of scale length and resolution. A reference multimeter on its 200 mV range can resolve 10 nV. Subject to noise limitations, it could measure two standards that were well over 100 mV apart and still resolve 10 nV. Electronic, Zener-based references are now widely used and often have outputs at the 10 V, 1 V and 1.018 V levels. Comparison between the different voltage outputs requires knowledge of the voltage ratio. Traditionally, high-precision voltage dividers would be used for this task, a known voltage at the 10 V level would be divided by a known ratio through the (calibrated) divider and compared at the 1 V or 1.018 V level using a microvoltmeter. The divider would have to be known for all the required ratios and would be adjusted to null the microvoltmeter. The reference multimeter can replace these instruments and simplify the measurement. Figure 2 shows the basic arrangement for comparing two standards at the 10 V level—the connections would be very

similar for 1 V or 1.018 V. Note that the arrangement is very similar to that described for comparing dc standards with a microvoltmeter except that now the reference multimeter (rather than a microvoltmeter) can handle large differences between the two devices without sacrificing resolution. There are no significant problems with this measurement provided that the reference multimeter isolation to ground does not load the output of either voltage reference and that a preliminary zero operation is performed to remove any residual offsets in the multimeter and its connecting leads. The configuration shown is effectively a potentiometric or differential measurement. The reference multimeter is configured to measure the difference between the two voltage references.

Ratio mode and rear inputs

The 8508A Reference Multimeter has two input channels that may be switched automatically to perform a ratio measurement. In ratio mode, the 8508A displays the ratio of the inputs in the form F-R (front minus rear), or F/R (front as a percentage of the rear), or (F-R)/R (the difference as a percentage of the rear). The most commonly used of these ratios is F/R (i.e. the front as a percentage of the rear). In this mode with, for example, 10 V connected to rear channel (reference) and 1 V connected to the front channel, the display would show +10.000 000 %. This is the ratio of the unknown 1 V to the known 10 V reference. Note that the reference multimeter is measuring the whole voltage for each channel and is configured to a single (20 V) range. The only error contributions to this measurement are the uncertainty of the 10 V reference standard, the noise and differential linearity of the reference multimeter and the

noise of the UUT 1 V standard. Typical noise of the reference multimeter is <50 nV pk/pk (7½ normal and 8½ fast adc modes) and differential linearity in 8½ digit mode is better than 0.1 ppm of full scale over a 10:1 ratio. These figures are similar to that which might be obtained by a skilled metrologist with a freshly calibrated voltage divider and microvoltmeter. The reference multimeter can make this measurement continuously and its linearity does not change significantly with time, so setup costs are lower and the measurements are automated, taking less time. Figure 3 shows how the reference multimeter can be used to measure the whole voltage of each reference by using identical multiple input channels in the ratio mode. Confirmation of the reference multimeter’s linearity beyond the 0.1 ppm level is difficult under normal circumstances. However, several instruments have now been evaluated against 10 V Josephson arrays. In this measurement, the Josephson system can be made to generate a series of voltages between 1 V and 10 V with uncertainties at least an order of magnitude better than most precision or reference multimeter’s linearity.

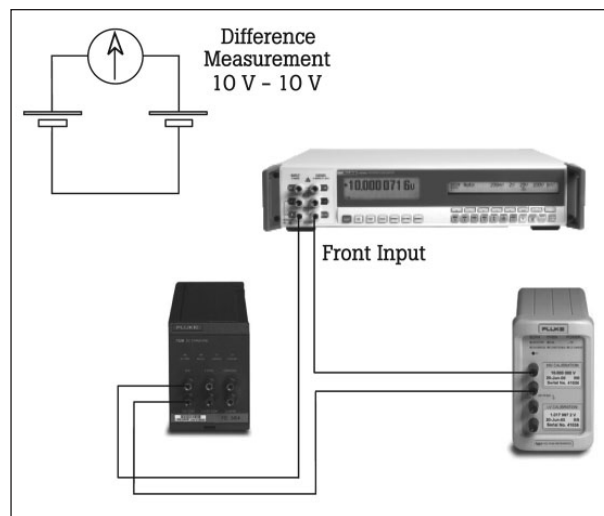

Fig. 2 The basic arrangement for comparing two standards at the 10 V level.

Resistance applications

Another very useful application of the reference multimeter is in resistance measurements. An 8½ digit reference multimeter has virtually the same linearity on its resistance function as for dc voltage, except, in this case, there are no resistance standards accurate enough to be able to prove resistance linearity in a conventional sense. One of the problems of trying to measure resistance linearity directly is the uncertainty of the individual resistor values. For example, measuring linearity on the 20 kΩ range of an 8½ digit reference multimeter with a maximum indication of 19.000 000 0 kΩ would require several different resistance standards. Assuming that measurements were to be made at a minimum of five evenly spaced points throughout the range, e.g. at zero, 5 kΩ, 10 kΩ, 15 kΩ, and 19.9 kΩ, the difficulties in finding suitable standards soon become obvious. Typically, resistance standards will be available at the normal decade values of 10 Ω (25 Ω may be available), 100 Ω, 1 kΩ, 10 kΩ, etc. and so do not provide even coverage throughout the range. When one considers that some DMMs have resistance linearity specifications of better than 0.3 ppm, and that individual resistance standards may have uncertainties of 1 ppm or more, test methods using separate resistors or decade boxes will be inadequate. For this reason, resistance linearity is not usually measured during routine calibrations of reference multimeters. However, linearity can be verified in the following way. Figure 4 shows the circuit configuration for resistance measurement used in a reference multimeter. The resistance option is primarily a range of selectable constant currents. A constant current generator forces a current I_x to flow through the test resistor R_x . A true constant current source will

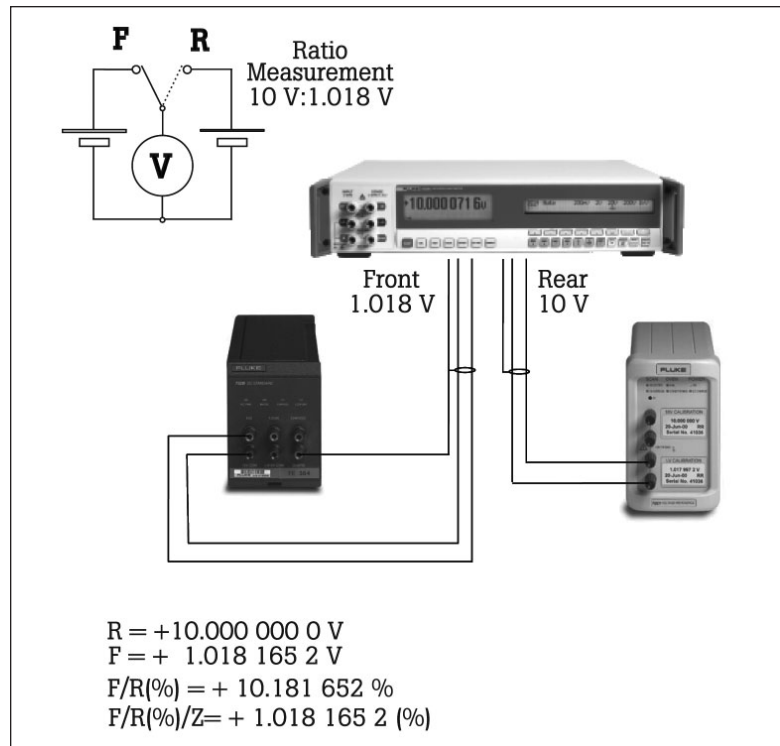

Fig. 3 Voltage ratio measurement.

generate a current independently of the voltage developed across its terminals, in this case designated Input Hi and Input Lo. It therefore follows that if a known resistance is applied to the reference multimeter and the display value noted, the insertion of an additional resistance in series with the Input Hi lead should not significantly

affect the multimeter's reading. This will confirm that the current source can deliver the same current through a range of resistance values. If it can also be confirmed that the voltage range used for the resistance measurement is also linear, there is then a technically sound way of confirming good resistance linearity without the

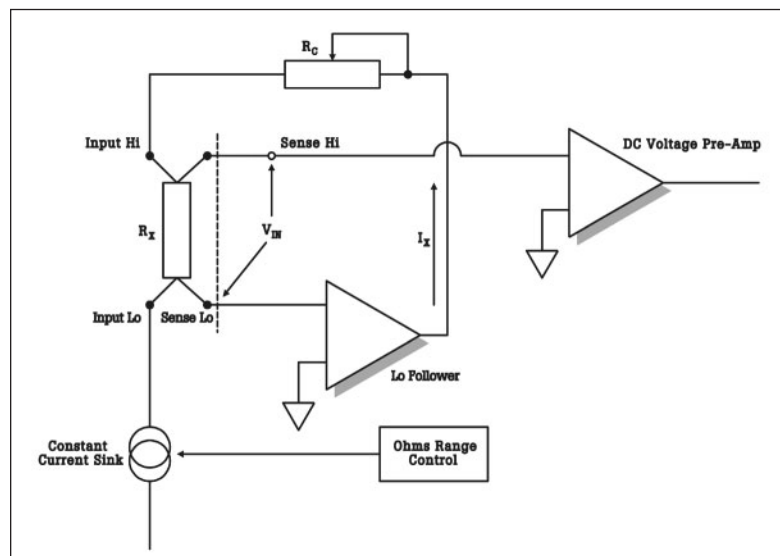

Fig. 4 Reference multimeter ohms converter.

need for a resistance linearity standard. Note that the series resistance does not need to be a precision resistor—it could be a low-noise potentiometer.

True ohms — avoiding thermal emf errors

A typical mistake is to confuse the four-wire and True Ohms resistance measurement techniques. However, the two principles are quite different and are used to avoid resistance measurement errors. It is customary in a metrology application to employ four-wire sensing techniques for measuring lower value resistors so that series lead resistance errors are eliminated. However, this technique does not take into account the effects of voltage offsets.

Voltage offsets are caused by junctions of dissimilar metals at different temperatures within the voltage measuring circuit. Typical sources might be within the resistor itself, or connecting leads and terminals. This is why temperature uniformity within a calibration laboratory is important. There will also be voltage offsets within the reference multimeter itself. A simple zero operation (a mathematical subtraction) before the measurement commences will remove all of these ‘static’ offsets.

These voltage offsets can also become ‘dynamic’ in their nature. Changes in ambient temperature due to draughts, airflow within a room or through an instrument or even variations in a room’s air-conditioning temperature can lead to offsets that are constantly changing.

Finally there are offsets which occur as a result of direct heating of the shunt resistor by the energizing current. Where large currents are involved, this can also give rise to thermoelectric effects (Peltier and Seebeck) in external connections too. These dynamic thermal offsets only occur when the current is flowing, but because

of their long thermal time-constant, can be measured. Traditional resistance bridge measurements use a specific process to isolate resistance from other unwanted parasitics i.e. voltage offsets. A typical arrangement would be to place the known and unknown resistors in series and pass a current through them. A voltage ratio measurement would then be made of the voltages developed across the potential terminals of each resistor. The current supply would then be reversed and the measurement repeated. The current reversal will cancel effects of the voltage offsets because in one polarity they would add to the measured voltage and in the reverse polarity would subtract from it. The average voltage ratio from the forward and reverse currents will remove the offsets.

Unfortunately, this reversal of current technique could only be found in expensive resistance bridges. Previous multimeter designs have attempted to overcome this problem using either True Ohms or Offset Compensated Ohms techniques. These methods essentially switch off the current source and take an additional voltage reading at zero current, then subtract this result digitally from the ‘current on’ voltage

reading, thereby eliminating the effect of unwanted offsets in the measurement path. However, this technique suffers the disadvantage that the measurement current switches at the read rate, modulating the power dissipation and temperature of the resistor under test. This effect can lead to significant errors when measuring certain types of resistors, particularly low values, and resistors that have large temperature and power dependencies—an example being platinum resistance thermometer elements.

However, the Fluke Calibration 8508A Reference Multimeter has enhanced resistance measurement capabilities and can now compensate automatically for any static or dynamic thermal emfs. The current reversal True Ohms technique has been developed and implemented, illustrated in figure 5. In this case, the current source is capable of being reversed. Each reading consists of two measurements, taken automatically under the control of the multimeter’s processor. The first reading is taken with the current in the forward direction, the second with the current in the reverse direction and the two measurements are averaged to provide the displayed result.

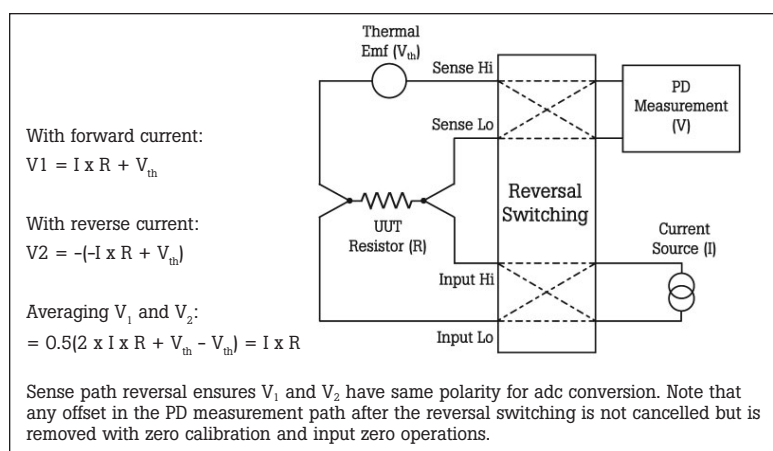

Fig. 5 Current reversal True Ohms.

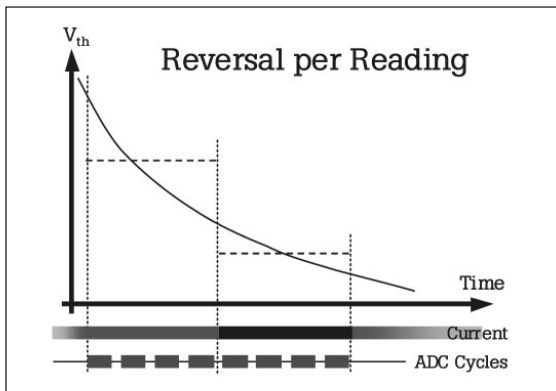

Fig. 6a Current reversal after each reading.

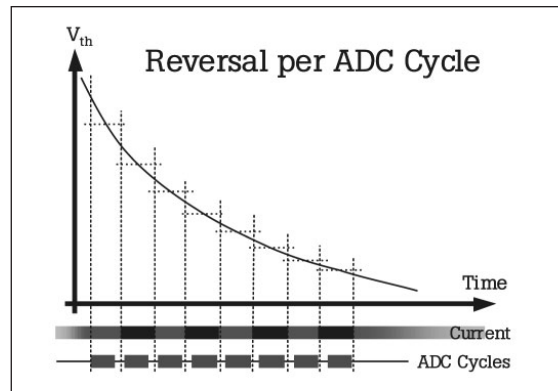

Fig. 6b Current reversal after each adc cycle.

The power dissipation in the resistance under test remains constant, as the current is never switched to zero. Not only is static thermal emf cancellation achieved, but changing thermal emfs are also cancelled.

As with the dc voltage function, when in the True Ohms function the user is able to select the resolution and adc mode, effectively controlling reading resolution and sample (integration) time. At the higher resolutions relatively long effective integration times would limit the effectiveness of the True Ohms thermal emf cancellation, if those thermal emfs changed significantly during the integration time. To avoid this situation at the higher resolutions where multiple adc cycles are digitally averaged, the current is reversed several times during the reading sequence, rather than just once. Figure 6a shows four adc cycles being averaged for a reading in each polarity with current reversal taking place after each reading. Figure 6b shows current reversal taking place after each adc cycle. The same number of adc cycles occur for each polarity, but the change in emf between consecutive polarity reversals is much smaller so cancellation is more effective.

Ohms guard

Another consideration when measuring higher value resistances is the effect of parallel leakages in the measurement circuit. Such leakages will divert some current away from the resistor being measured and cause an error in the measurement. A reference multimeter's ohms guard can effectively remove the effects of leakage provided that a suitable connection for the guard is available.

The 8508A Reference Multimeter's resistance function has an 'Ext Grd' option that can be selected to make the Guard terminal function as Ω Guard. Figures 7 and 8 show the 8508A Reference Multimeter's Ohms guard in use. The

Lo Follower will maintain Lo and Analog Common (0 V) at the same potential by forcing more current through Rx and Ra until Lo is at 0 V ($I_b=0$). The calibrated current I_x will then be flowing through R_x . Note that where the connection lead insulation is suspect, running Input Sense and Input Hi in one shield, and Input Sense and Input Lo in another, while connecting both shields to ohms guard, will remove any leakage between Input Hi/Sense Hi and Input Lo/Sense Lo (See Figure 8). This is because the leakage is 'seen' as a parallel resistance path with a convenient tapping (the cable screens) for ohms guard. Provided the current leakage resistance path is

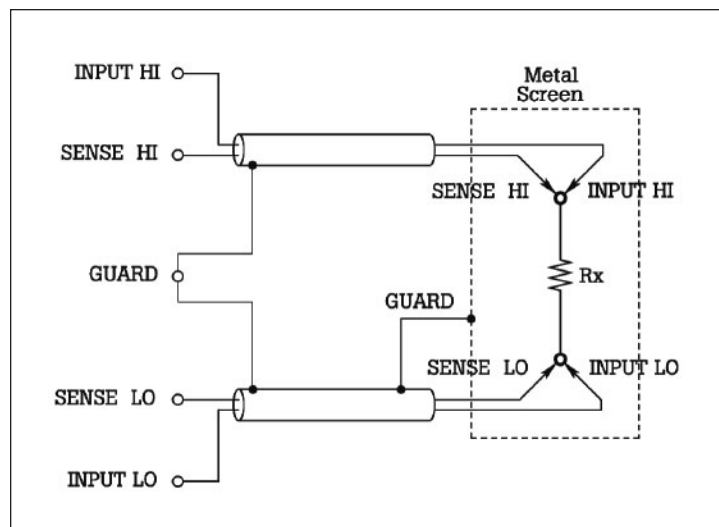

Fig. 7 Ohms guard connections.

greater than 250 Ω, not only will the leakage current be sourced from the Lo follower (as I_a), but any lead capacitance charge current will also be driven resulting in reduced settling times for high value resistors.

Resistance transfers and ratio

The Ratio function is available on the 8508A's Resistance function. Furthermore, ohms guard is also available on the reference multimeter front and rear inputs and is used to eliminate lead leakages from high resistance measurements. When combined with ratio switching, very high accuracy automated resistance transfers can be performed for both 1:1 and 10:1 ratios. In either case, the reference multimeter will be configured for the appropriate resolution (5½ to 8½ digits), adc speed, ohms source current, analog/digital filter and ratio mode for the particular resistor values concerned. The range selection will be chosen to accommodate the higher of the two resistor values. For example, a 10 kΩ to 1 kΩ ratio will use the reference multimeter's 20 kΩ range—the multimeter's excellent linearity will ensure the maximum transfer accuracy between the two values. Figure 9 shows the reference multimeter configured via the front and rear input terminals to compare two resistance standards using resistance ratio.

True Ohms ratio

A unique extension to the True Ohms and ratio capability has now been incorporated into the 8508A Reference Multimeter design as a means to avoid voltage offsets, and the thermal effects of power modulation in the resistances being measured as the stimulus and measurement are scanned between the two channels. Instead of switching stimulus current between channels, the

two channels are effectively configured in series, as shown in figure 10, so that the stimulus current flows continuously through both resistances being measured. Only the potential difference measurement is scanned, measuring the ratio of the voltage across each resistor with the same constant current flowing continuously through both. The power dissipation in either resistor is constant

throughout, regardless of which part of the measurement cycle is being executed. This technique is most beneficial on the lower resistance ranges where stimulus currents are higher, for example 100 mA on the 2 Ω range. Because lower value resistors are typically measured at relatively low voltages, thermal emf errors can also be more significant, so this special ratio feature is combined with the

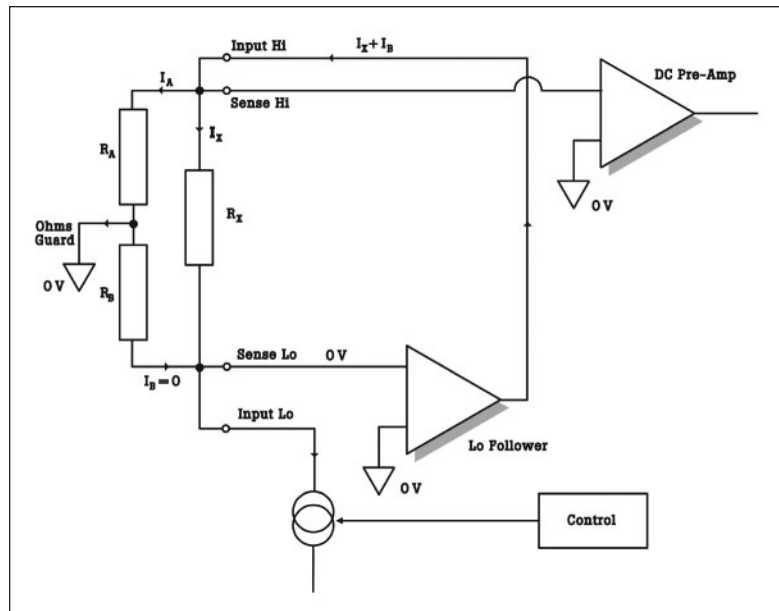

Fig. 8 Ohms guard operation.

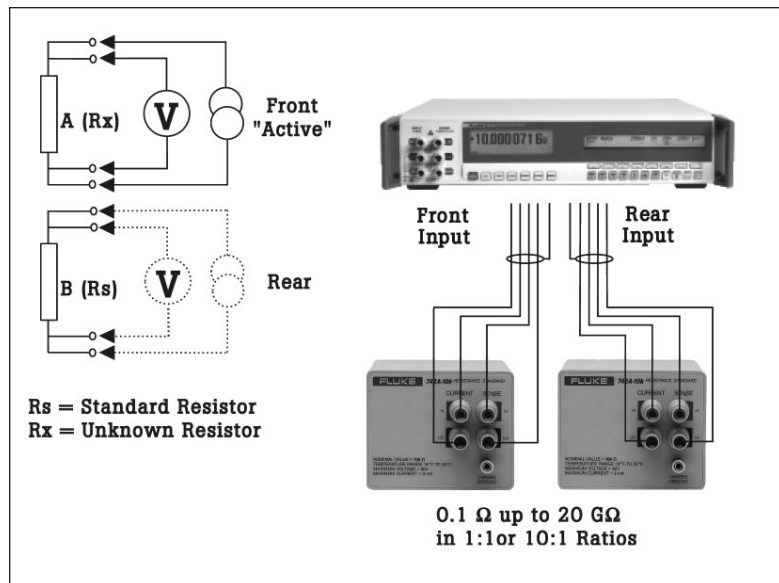

Fig. 9 Resistance ratio.

but for the utmost accuracy a transfer could easily be made to a resistance standard connected to the rear input. Note that the front input could also be used for either resistor. A two-wire, six-dial decade box of nominally 10 kΩ would require four ranges of the reference multimeter to be used. The reference multimeter would be used in the True Ohms mode with the ranges and resolution set as shown in Table 1. First, a four-wire zero would be made by connecting Sense Hi and Input Hi to Input Lo and Sense Lo at the decade box Lo terminal. The input zero is then used to remove any residual resistance offset. The multimeter Input Hi and Sense Hi wires would then be moved to the resistor Hi with

all decades set to zero. The multimeter will indicate the true zero error of the decade box. After recording the zero value, the resistance offset will be removed by the input zero function and each decade measured in turn at each dial setting up to a maximum of 11.1111 kΩ. Note that from the resolution table, the relative accuracy of this measurement is very high, and because the reference multimeter resolution is adjusted for each decade, it will also be very fast.

High voltage resistance measurements

By increasing the output voltage drive capability of the Lo Follower in figure 8, the ability of the system to measure high

resistances can be significantly improved, with ranges up to 20 GΩ. In previous implementations of this topology the maximum voltage was 20 V, but the 8508A design increases this to over 200 V. Therefore when using the 8508A's Hi voltage resistance function, extreme caution must always be taken, as voltages on the input terminals can potentially reach well in excess of the nominal 200 Vdc.

This technique requires use of the higher voltage ranges within the dc voltage measurement sub-system (the 200 V range) with an input impedance of approximately 10 MΩ. However, this relatively low impedance, in comparison with the resistances to be measured

Dial #	Step value	Decade maximum	Reference multimeter range	Reference multimeter digits	Measurement resolution % of step	ppm of kΩ
1	1 kΩ	10 kΩ	20 kΩ	7.5	0.0001	0.1
2	100 Ω	1 kΩ	2 kΩ	6.5	0.001	0.1
3	10 Ω	100 Ω	200 Ω	5.5	0.01	0.1
4	1 Ω	10 Ω	20 Ω	5.5	0.01	0.01
5	0.1 Ω	1 Ω	2 Ω	5.5	1	0.1
6	0.01 Ω	0.1 Ω	2 Ω	5.5	10	0.1

Table 1 Decade box and reference multimeter resolution.

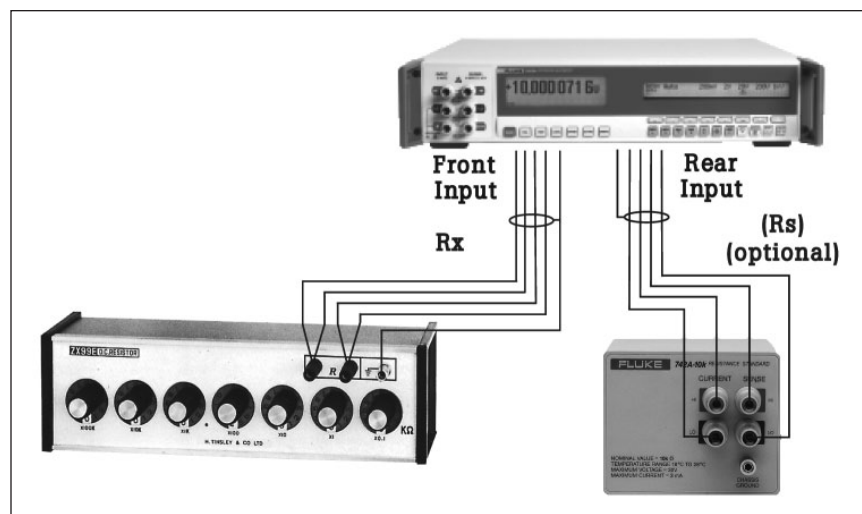

Fig. 12 Decade box calibration.

(up to 20 GΩ), is not a problem as any input current taken by the dc voltage measurement sub-system is simply supplied by the Lo Follower output via the Input Hi terminal, which does not affect the stimulus current provided by the current sink via the Input Lo terminal. Measurement of high resistances at higher voltages improves noise performance, reduces the impact of leakages (because the stimulus current is higher) and allows evaluation of resistor voltage coefficients by making measurements of the same resistor in both normal and high voltage resistance modes.

Low burden ‘Virtual Earth’ current measurement techniques

The majority of multimeter instrument designs, including Precision DMMs, utilize the ‘shunt’ method of current measurement, as illustrated in figure 13. Here, the input current is passed through a shunt resistor R_s and the voltage developed across the shunt (V_s) is applied to the multimeter’s ac or dc measurement circuit. A multi-range instrument uses different values of R_s for each range. Sufficient voltage must be developed to ensure adequate measurement, but this voltage also appears at the current input terminals as the burden voltage V_{in} . Developing a high burden voltage can disturb the conditions in the circuit where the current is being measured when the DMM is inserted to make the measurement. Any external stray capacitance present between the input terminals (such as lead capacitance) effectively appears across the shunt, and is exposed to V_o . For lower current ranges the relatively high impedance values of the shunts increase the susceptibility to stray capacitance and can

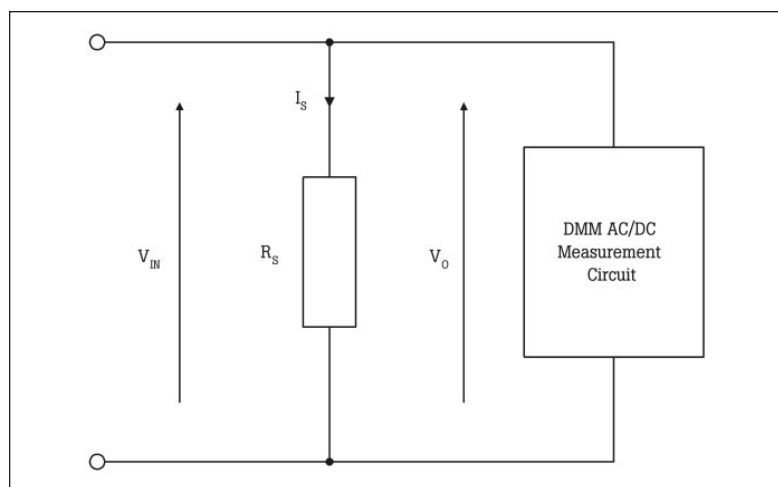

Fig. 13 Conventional DMM input ‘shunt’ configuration.

cause frequency response degradation. The design of a new generation reference multimeters has addressed these issues.

The Fluke Calibration 8508A uses a ‘virtual earth’ current measurement technique (figure 14) on the 200 μA, 2 mA and 20 mA ranges. This method essentially minimizes the burdens previously associated with the ‘shunt’ method and significantly reduces the input resistance. Here, the input current passes through the feedback resistor (R_s) of an inverting amplifier, and the voltage developed at its input (the virtual earth) is zero, effectively isolating the input burden voltage from the voltage developed across the shunt

R_s . The output voltage V_o is $I \times R_s$, which can now be made sufficiently large for measurement by the voltage measuring circuits. The virtual earth current measurement topology brings greatest benefits for the lower current ranges where the shunt resistance values are relatively high. For the higher current ranges the ‘shunt’ topology can be used successfully and is employed in the Fluke 8508A for 200 mA, 2A and 20 A ranges.

For the operator there are two main advantages of using a current measurement with ‘virtual earth’ input. Firstly, and as discussed above, with an input resistance of virtually zero, current measurements are far less invasive, disturbing

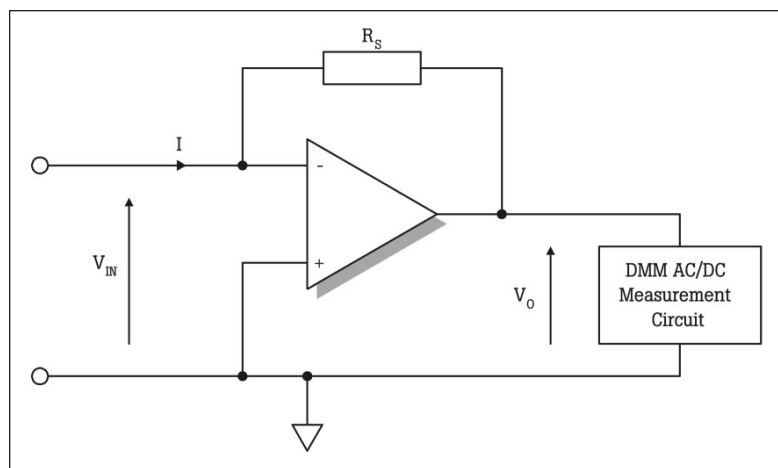

Fig. 14 Ammeter input ‘virtual earth’ current configuration.

the conditions less when the multimeter is inserted into the circuit, because the voltage developed across the multimeter current input is much less. But secondly, guarding arrangements are also simplified. This is because there is less opportunity for leakage errors to take place, as the voltage developed across the multimeter input is much lower. Leakage errors typically become a problem when measuring ac currents at higher frequencies due to stray capacitance in the cables used to make connection to the multimeter.

Solving the problem of self heating in current measurements

Most general-purpose multimeters of 3 or 4½ digit resolution can measure both ac and dc currents up to 20 A at modest accuracy levels. The temperature coefficient characteristics of the current shunts and the self-heating effects due to power dissipation in the shunts limit linearity and settling time performance, adversely affecting the multimeter's accuracy. Consequently, high current ranges are usually absent from higher precision multimeters.

Using state of the art techniques, Fluke Calibration designers have successfully overcome these obstacles, allowing metrologists to make practical high current measurements directly with the 8508A Reference Multimeter. The 8508A Reference Multimeter utilizes high accuracy current shunts with extremely low temperature coefficients and minimal power dissipation. Careful design of surrounding circuitry and thermal management has optimized settling time and linearity performance consistent with the requirements for metrology applications.

High current measurements

One of the new features to come out with the launch of the new generation reference multimeter is that of higher current measurement on both ac and dc current ranges. Previously, all leading edge Precision DMM's could only measure current to 2 A full-scale, which posed a real problem for applications that required current calibration of 2 A or more. For example, calibrating the ac or dc current ranges of a multi-product calibrator had always been a two-stage affair. Typically, current ranges up to 2 A would have been calibrated using any precision long-scale DMM as normal. However, multi-product calibrators like the Fluke Calibration 5522A have ac and dc current ranges to 20 A and therefore could not be calibrated by just a Precision DMM alone. This higher current 20 A range would require the use of a suitably calibrated current shunt connected to the long-scale precision DMM, set to the appropriate voltage range at the full-scale current passing through the shunt.

The 8508A Reference Multimeter can measure both ac and dc currents to 20 A full-scale thereby, eliminating the need for external current shunts and connection cables, and so making the process of high current measurement a lot easier to prepare and perform.

Using the reference multimeter as a high accuracy temperature calibration tool

Reference multimeters like the 8508A can now offer the metrologist another string to their high accuracy measurement bow. The highly accurate temperature measurement function on the 8508A allows the user to perform a further

two more calibration functions. Firstly, when coupled to a PRT (Platinum Resistance Thermometer) device with known characteristics, the reference multimeter can be used simply as a means to read a temperature being measured by the PRT. This is useful when calibrating temperature sources like dry wells. Secondly, the reference multimeter can also be used to calibrate PRT or SPRT (standard platinum resistance thermometer) probes. And with two inputs, comparisons and transfer measurements are simple.

Prior to making any temperature measurement, the PRT or SPRT's coefficients and configuration must be entered into the reference multimeter. The 8508A Reference Multimeter can store up to 100 probe settings, all of which can be edited or deleted as required. It can also be set up for a 2, 3 or 4-wire PRT or SPRT probes and for values of 25 Ω or 100 Ω. For high accuracy SPRT calibration applications the ITS-90 sub ranges are supported, as too are the Callendar van Duesen conversion algorithms for PRT probes for all industrial applications. The 8508A provides a temperature readout by measuring the resistance of the PRT or SPRT probe connected, and converting the resistance value to temperature. The multimeter will auto-range between the 200 Ω 'Lo I' Ohms range and the 2 kΩ 'Normal' Ohms range depending on the resistance value obtained at the temperature being measured. Current reversal True Ohms is used with a stimulus current of 1 mA. The 8508A Reference Multimeters can also be set up to display one of three user selectable units of measure—degrees Centigrade, degrees Fahrenheit or Kelvin, at up to 8.5 digits resolution.

PRT probe calibration data and flexibility

The Fluke 8508A Reference Multimeter can be supplied with an extended range SPRT or a secondary standard PRT probe from Fluke’s Hart Scientific Division. Alternatively, these probes can be purchased as Fluke 8508A accessories. All probes are supplied with a detailed certificate of calibration containing the coefficients needed for the temperature conversion algorithms, obtained by calibration at low uncertainty against Hart’s temperature and resistance standards. To use with the Fluke 8508A, the probe coefficients must first be entered into the reference multimeter, so that the resistance to temperature conversion algorithms can correctly convert the resistance values obtained for that particular probe, into accurate temperature readings.

Having probes calibrated independently from the reference multimeter provides users the flexibility to use any other probe of appropriate resistance with the reference multimeter, and not just the probe supplied. Measurement uncertainty is not sacrificed, as the route for temperature traceability

through the established conversion algorithms is based on resistance measurements at specific temperatures, and not a direct temperature measurement. Directly calibrating the 8508A together with a specific probe would not yield better temperature measurement uncertainties, but would mean a significant loss in flexibility when using other probes.

An electrical and temperature metrology measurement in one single solution

The reference multimeter has many benefits, particularly for users with both electrical and temperature calibrations to perform.

When used with an SPRT or PRT probe, the reference multimeter’s PRT function is ideal for precision temperature measurements and calibrations. The two-channel ratio capability available in the True Ohms function can also be used to compare PRT probes directly in terms of their resistances. However, if measurement of several PRT probes simultaneously is required, then one of the many multi-channel precision thermometry solutions offered by Fluke Calibration would be ideally suited.

Summary

Since the introduction of the 8508A the reference multimeter is now being seen as the natural replacement for many of the traditional measurement methods currently used in electrical metrology laboratories worldwide. Already, the 8508A Reference Multimeter can be found in national standards labs, commercial laboratories and even militaries around the world. With greater accuracy and stability, versatility and ease of use the reference multimeter is now seen as the ideal investment or long-scale DMM upgrade for any electrical metrology based application or laboratory. And with yet more functionality, the reference multimeter is a much more attractive and cost effective alternative to the metrologist’s former favorite—the precision, long-scale DMM.

8508A Reference Multimeter



Reference standard accuracy and stability, in one functionally versatile, easy to use solution

Fluke Calibration.

Precision, performance, confidence.™

- ▶ Electrical
- RF
- Temperature
- Pressure
- Flow
- Software

Fluke Calibration
PO Box 9090, Everett, WA 98206 U.S.A.

Fluke Europe B.V.
PO Box 1186, 5602 BD
Eindhoven, The Netherlands

For more information call:
In the U.S.A. (877) 355-3225 or
Fax (425) 446-5116
In Europe/M-East/Africa +31 (0) 40 2675 200 or
Fax +31 (0) 40 2675 222
In Canada (800)-36-FLUKE or
Fax (905) 890-6866
From other countries +1 (425) 446-5500 or
Fax +1 (425) 446-5116
Web access: <http://www.flukecal.com>

©2003-2011 Fluke Calibration. Trademarks are the property of their respective owners. Specifications subject to change without notice.
Printed in U.S.A. 9/2011 2090893C D-EN-N
Pub-ID: 10757-eng

Modification of this document is not permitted without written permission from Fluke Calibration.